

8 7 6 5 4 3 2 1

ROLL DIMENSION: METHOD 1

FORMULA:
 $(L - (\frac{1}{2}ROLL)) * \sin(ANGLE) = 1$
 $(H - (\frac{1}{2}ROLL)) * \cos(ANGLE) = 2$

$1 + 2 - (\frac{1}{2}ROLL) = ROLL DIMENSION$

NOTE: SINE BAR IS SET TO GIVEN ANGLE.
 ANY TARGET POINT MAY BE USED
 AS LONG AS H AND L VALUES CORRESPOND
 TO THIS POINT.

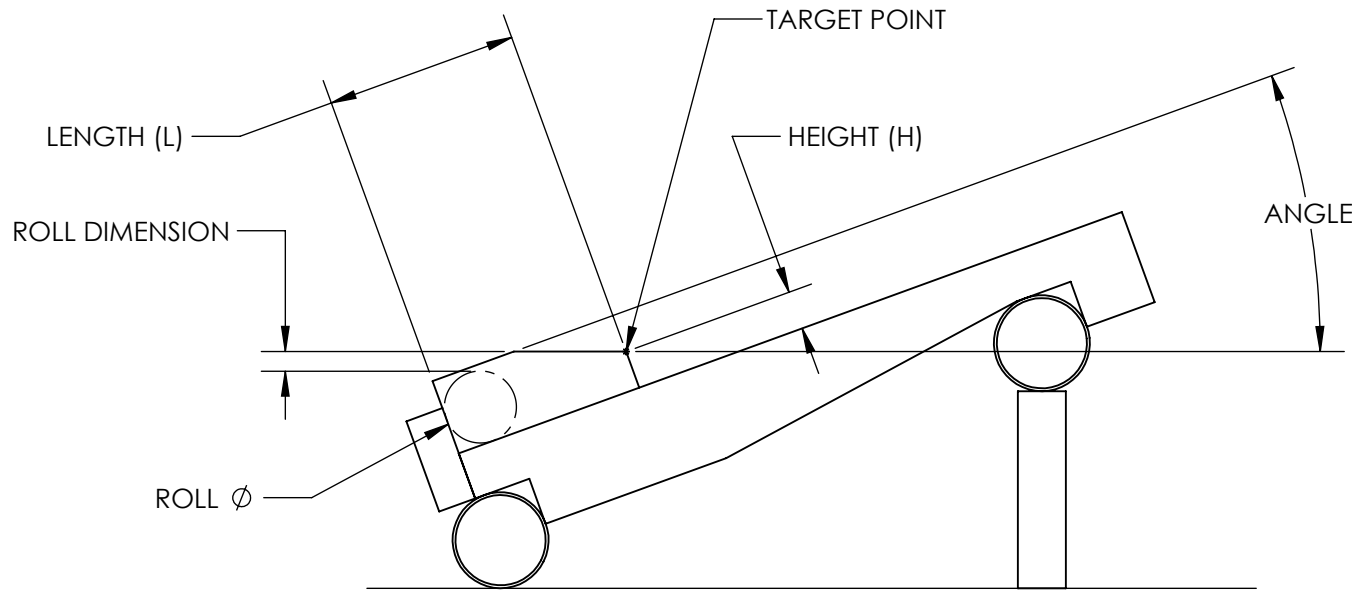

UNLESS OTHERWISE SPECIFIED DIMENSIONS ARE IN INCHES
 TOLERANCES FOR BOTH SYSTEMS ARE:

ENGLISH:		METRIC:		ALL ANGLES
FRACTIONS	DECIMALS	DECIMALS		
± 1/32	.XX ± .01	X.X ± 0.1		X ± .1°
	.XXX ± .002	X.XX ± 0.01		.XX ± .05°
	.XXXX ± .0002			

Raystown Precision Tool 

1822 Washington Street
 Huntingdon, PA 16652

MATERIAL: **N/A**

FINISH: $\sqrt{32}$

DO NOT SCALE DRAWING

DRAWN BY: NWE
 APPROVED: _____

DATE: 9/01/2015
 DATE: _____

ROLL DIMENSION: METHOD 1

SIZE: **A** DWG. NO.: **RPT0001** REV. **A**

SCALE: XX FILE: SHEET 1 OF 1

A			Initial Release	NWE	9/01/2015	
PART #	REV #	ECN	CHANGE DESCRIPTION	REV. BY	ECN DATE	CHECKED

THE INFORMATION CONTAINED IN THIS DRAWING IS PROPRIETARY AND THE SOLE PROPERTY OF RAYSTOWN PRECISION TOOL.
 ANY REPRODUCTION IN PART OR WHOLE WITHOUT THE WRITTEN PERMISSION OF RAYSTOWN PRECISION TOOL IS PROHIBITED.

8 7 6 5 4 3 2 1